

# Pro-Series Mailbox System Installation Instructions

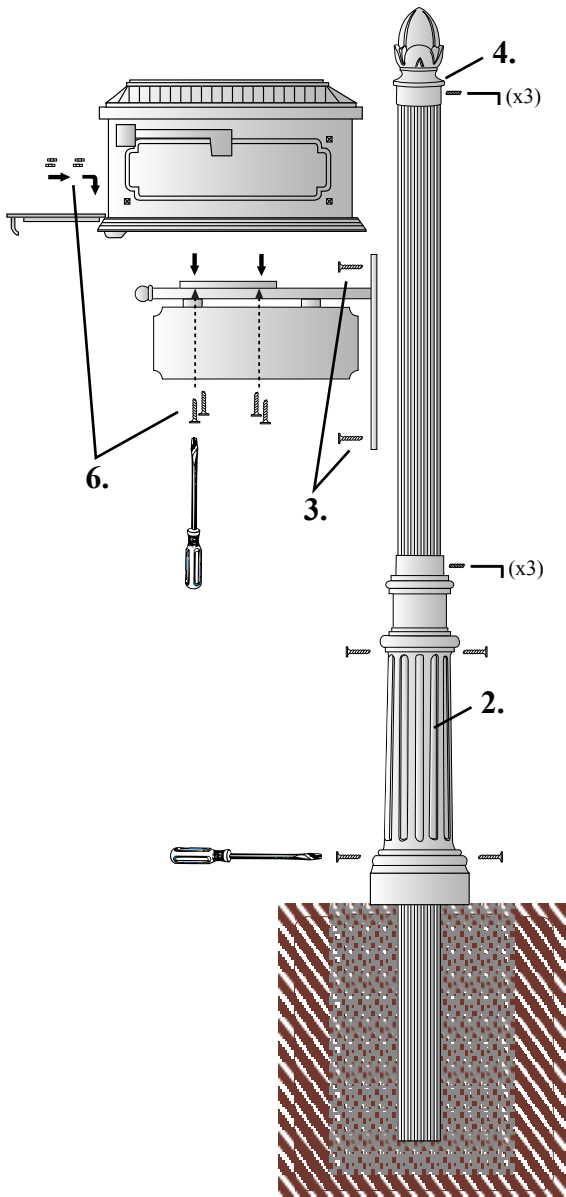

Side View

Generally, mailboxes should be installed at a height of 41–45 inches from the road surface to the bottom of the mailbox or point of mail entry. Mailboxes are set back 6–8 inches from the front face of the curb or road edge to the mailbox door. Due to varying road and curb conditions and other factors, the Postal Service suggests contacting the local Post Office™ if you have questions on location and positioning.

## Installation instructions for direct burial mailbox assembly

1. Prepare post hole to 18" -24" depth.
2. Attach wrap around base to lower portion of post leaving approximately 18" from post bottom to base bottom. Tighten set screws sufficient to hold base in place. DO NOT fully tighten. (Skip this step if base is welded to post).
3. Attach mounting bracket(s) to post by aligning bracket holes with post screw/grommets.
4. Attach post topper by tightening set screws around top of post (skip this step if topper is welded to post).
5. Affix address numbers (if available).
6. Attach mailbox to post bracket plate using nuts/bolts provided.
7. Place assembled unit into posthole with bottom of mailbox door positioned 41- 45" above road surface and set back 6 – 8" from face of curb.
8. Insert dry post-hole concrete mix per bag instructions around the mailbox post. Do NOT add water yet!
9. Align all components, tighten hardware and level the assembly.
10. Follow remaining instructions per concrete mix, re-check that mailbox post has remained level.

## Tools required for assembly

- Phillips head screw driver
- Adjustable or combination wrench
- Hex or Allen wrench
- Small level